

PERFINOX

SOLUTIONS FOR THE FOOD INDUSTRY

PERFISAFE

ASEPTIC STORAGE



PERFIPROCESS[®]

by PERFINOX | www.perfinox.pt



PERFISAFE

ASEPTIC STORAGE

OVERALL DIMENSIONS

20m³ UNIT

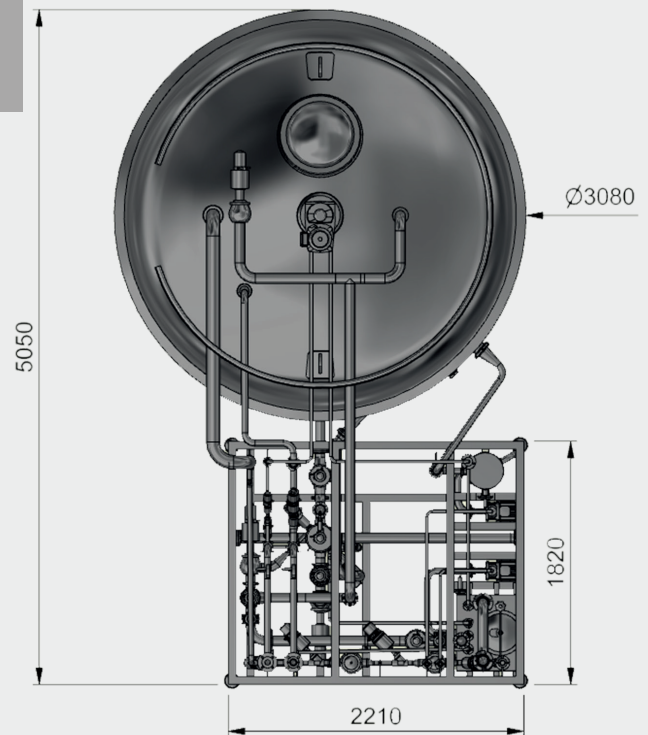

High efficiency pressurized tanks, designed for aseptic storage and integration of optional auxiliary systems, depending on customer needs and requirements.

FEATURES

- Safe and Sterile Storage
- Efficient CIP and SIP
- Low and high viscosity products handling
- Vacuum/Pressure Design
- Multiple options and designs
- Several capacities



PERFIPROCESS®

by PERFINOX | www.perfinox.pt



PERFINOX

www.perfinox.pt

perfinox@perfinox.pt

www.linkedin.com/company/perfinox

(+351) 256 928 145